



## **SD SERIES**

Solid Frame Crank Servo Press

## **SDG SERIES**

Straight Side Crank Servo Press

## **SDE SERIES**

Straight Side Eccentric Gear Servo Press



# SEYI's Customized Total Solution for Our Valuable Customers



## SEYI Servo Press + Transfer System + Feeder + Quick Die Change System

SEYI Servo Presses can easily integrate with different kinds of peripheral equipment, assisting our customers to achieve better production.

- |                    |                     |
|--------------------|---------------------|
| 1 SEYI Servo Press | 4 Die Changing Cart |
| 2 Feeder           | 5 Decoiler          |
| 3 Transfer System  | 6 Scrap Conveyor    |



Scan me

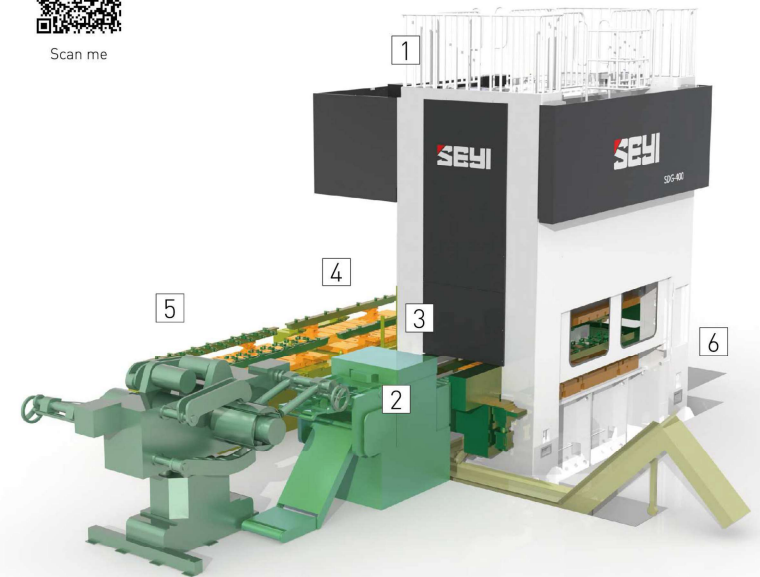

## Flexible and Capable to Meet Different Requirements

SEYI can provide a complete tandem line after a comprehensive evaluation of the customer's production method and environments. We provide systematic and flexible integrated solutions, including different types and tonnage presses to adapt to challenging requirements.

### Our Advantages:

- Simultaneous / Cooperative control for multiple servo presses.
- The machine height of a tandem line would be lower than a single large press, lessening the factory construction cost.
- Servo and mechanical presses can be combined.

Take the small tonnage press line (at least 4 units) for example. The line not only matches the production in high tonnage, but also surpasses the productivity of a large-tonnage press. Customers do not need to prepare the foundation pit, saving the investment in factory construction.

By implementing a tandem line layout, the original transfer die configuration can be changed to one die, one station. This can effectively lessen eccentric load, which improves the quality of stampings, shortens the time for tool adjustments, and reduces the tool maintenance costs.



Large-tonnage press line Illustration



Small-tonnage press line Illustration



Scan me

# SEYI's Eco-Friendly and Efficient Servo Press Benefits Customers

With an upward trend in environmental protection and power saving around the world, SEYI has been motivated by the mission to develop the world-class servo press. SEYI has utilized the latest technology in order to provide our customers with sophisticated, energy-saving and intelligent products. SEYI servo presses feature a direct drive transmission and a rigid frame design to reduce the total clearance. These presses are equipped with the most efficient servo motors that are only for servo presses.

## Direct-Drive Transmission

- SEYI servo motors integrate the pinion shaft directly into the motor
- Accuracy exceeds JIS1 level

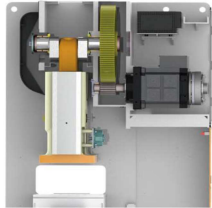

## Servo Motor

- Low Revolution Speed · High Torque
- Compact Size · High Efficiency
- Reduces power consumption
- Power regeneration
- Green equipment
- Excellent acceleration and deceleration
- The highest motor torque in the industry



## Advanced Press Structure Enhancement-Perfect for New Materials

- SD Series-RIBBED frame design  
Load balance to increase vertical and sidewall strength
- SDG/SDE Series -3 piece tie-rod frame structure  
High rigidity suitable for high-tensile steel stamping

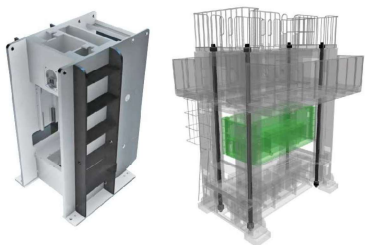

## Energy Saving & Low Electrical Power Consumption

Compared with a traditional press, a SEYI servo press can provide significant savings on electricity costs.

		Servo Press	Mechanical Press	Hydraulic Press
Total Voltage	KVA	240	208	277
Power Consumption per Hour	kWh	48	83	194
Power Consumption per Year	kWh	359,000	622,000	1,451,000
Yearly Electricity Cost (Japan)	Yen (¥)	8,687,800	15,052,400	35,114,200
Yearly Electricity Cost (USA)	US (\$)	43,080	74,640	174,120

\*The calculation is based on a 1200ton servo press running 24 hours per day and 312 working days per year.  
\*The data is based on SEYI's assumptions. The actual expenses are subject to regions and applications.

# User-Friendly Interface and Software

SEYI's user-friendly design on the HMI interface makes press operation simple and clear. Under each job number, all the corresponding parameters and settings, such as the motion profile, timing switches, tonnage monitor, die protection will be stored and saved in the servo press control system. When searching for a specific job number, all the settings for this tool will be shown on the HMI.

## Easy-to-Use Interface

Operators can easily set the profile parameters in the system to optimize complex stamping processes.

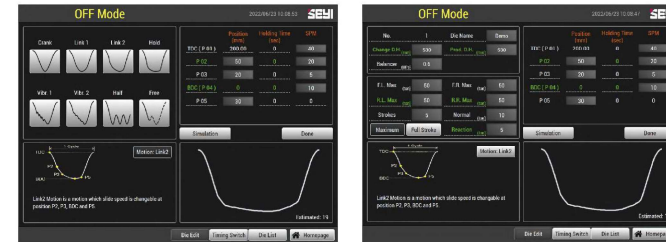

## Integrated Tonnage Monitor Function



- Set individual tonnage limits for each point and reverse tonnage limits
- Automatic setting of tonnage limits

## Integrated Die Protection



- Supports NPN/PNP signals
- Set detection timing and type
- Set stop type (E-stop or Top stop)
- Timing switch to set up the timing zone for any specific functions

\*All specifications are subject to change without notice. Please check with your supplier for exact offers. Products may not be available in all markets.

# Stamping Samples By SEYI Servo Press

## Twice the Productivity & Lower Power Consumption

Forming by pendulum mode-Half Motion

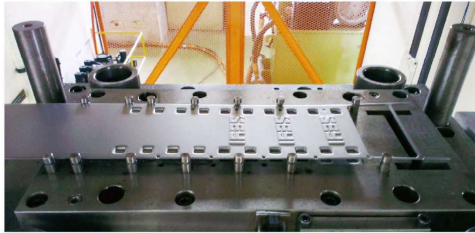

Compared to traditional presses, SEYI servo presses can eliminate unnecessary press movement, double the production output, and save about 50% on electrical power consumption while running progressive dies with Half Motion.



### Half Motion:

By taking the advantages of the servo press and the servo motor, the stamping stroke can be shortened.

## Deep Drawing: High Accuracy and Quality

Forming by vibration-Vibration Motion

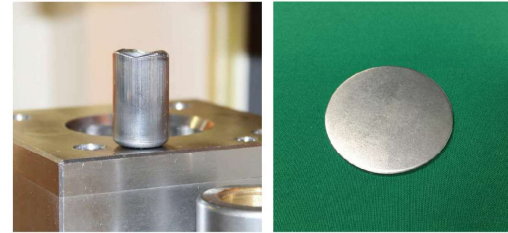

Deep drawing products require high accuracy and quality. Precisely controlling the slide motion is necessary to achieve better accuracy and a smooth surface with low heat. This method can improve production efficiency. For example, this part only needs a single working process instead of five processes.

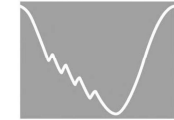

### Vibration Motion:

- Especially suitable for deep drawing
- Available in all SEYI servo presses, regardless of tonnage
- Precise control of the vibration speed and range

## Extrusion: Better Formability of Special Materials

Forming by holding pressure- Hold Motion



Hold motion on the servo press is suitable for special materials such as aluminum alloys and perform much better than traditional presses. Multiple stations are not necessary to complete this operation. For example, this work piece only needs a single process.



### Hold Motion:

- Suitable for cold and hot forming
- BDC accuracy of 0.01mm (Able to dwell at BDC for extended time)

## Bending: Spring Back Effect Improvement

Forming by restriking-Free Motion

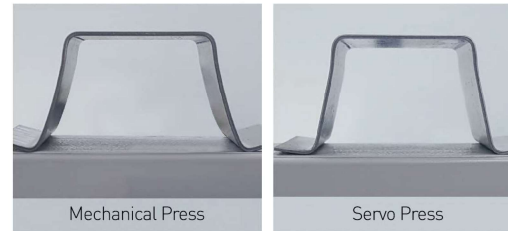

The stress of high-tensile steel can be eliminated via the repeated stamping on the same stage, effectively reducing the spring back effect. The spring back control of this work piece is within 0.3 degree.



### Free Motion:

The stamping curve can be set up by customers themselves based on the condition of different tools.

## 7 Pre-programmed Motion Profiles and 1 Free Motion curve

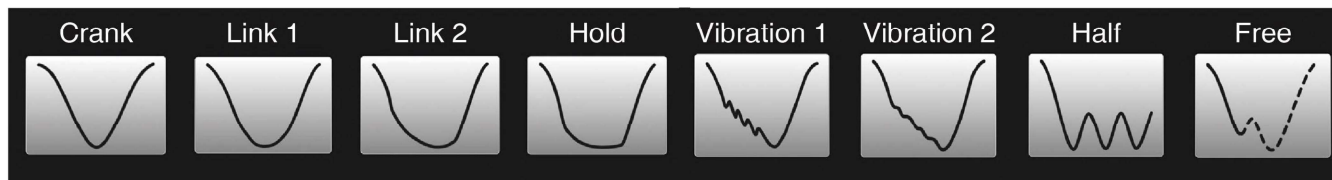

# SD1 series



Model		SD1-80	SD1-160	SD1-200	SD1-300	
Capacity	kN	800	1600	2000	3000	
Stroke Length	mm	180	220	250	300	
Strokes per Minute	SPM	~80	~60	~50	~40	
Tonnage Rating Point	mm	5	6	6	6	
Die Height	mm	330	400	450	550	
Slide Adjustment	mm	80	100	110	120	
Slide Area (LR x FB)	mm	700 x 460	900 x 580	1000 x 670	1150 x 800	
Bolster Area (LR x FB)	mm	950 x 680	1150 x 760	1300 x 870	1450 x 1050	
Bolster Thickness	mm	140	165	180	200	
Bolster Height (w/ Mounts)	mm	989	1054	1134	1154	
Window Opening (FB x UD)	mm	680 x 280	760 x 350	870 x 400	1050 x 450	
Floor Space Required	mm	1961 x 2050	2161 x 2557	2224 x 2761	2414 x 3157	
Total Height (w/ Mounts)	mm	3050	3610	3985	4460	
Max. Upper Die Weight	kg	300	500	800	1300	
Required Air Pressure	MPa	0.5	0.5	0.5	0.5	
Die Cushion	Capacity	kN	60	80	100	140
	Stroke Length	mm	95	110	130	140
	Cushion Pad Area (LR x FB)	mm	480x340	560x370	700x450	700x450

## Standard Features

- Servo System
- Safety Brake System
- Electrical Overload Protection
- Tonnage Monitor
- Programmable Motion Profiles
- Job Storage Capacity - Up to 200
- Die Height Adjustment
- Slide Position Adjustment(Handy Pulser)
- Portable Operation Stand
- Misfeed Socket
- Pneumatic ejector
- Safety Light Curtain
- Oil Lubrication System
- Total/Preset/Batch/Maintenance Counter
- Anti Vibration Mounts
- Safety Block
- Die Lamp
- Tool Box

## Optional Features

- Hydro-pneumatic Die Cushion
- Quick Die Change System
- Safety Door
- Hydraulic Die Cushion
- Lamp Socket
- NDC (Servo Die Cushion)
- Rear Safety Guard

## Slide Area & Bolster Area

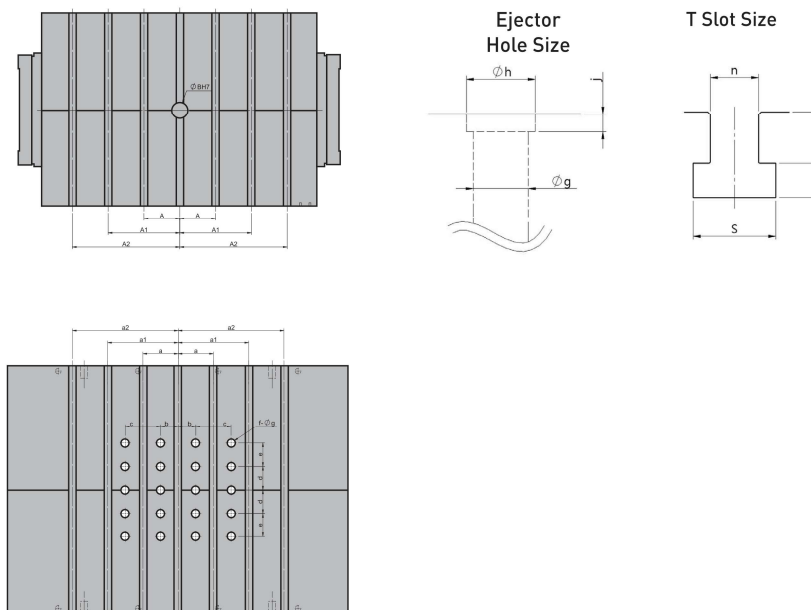

Unit: mm

Model		SD1-80	SD1-160	SD1-200	SD1-300
Bolster	a	150	150	150	150
	a1	300	300	300	300
	a2	-	450	450	450
	b	75	75	75	75
	c	140	150	150	150
	d	45	50	100	100
	e	90	100	100	100
	f (LRxFB)	4x5	4x5	4x5	4x5
	Øg	32	32	32	32
	Øh	40	40	40	40
	j	10.5	10.5	10.5	10.5
	n	28	28	28	28
	p	30	30	30	30
	q	20	20	20	20
	s	48	48	48	48
Slide Area	A	150	150	150	150
	A1	240	300	300	300
	A2	-	-	-	450
	ØB	50.8	65	65	65

# SD1 Series Curve Diagram

## Tonnage Curves

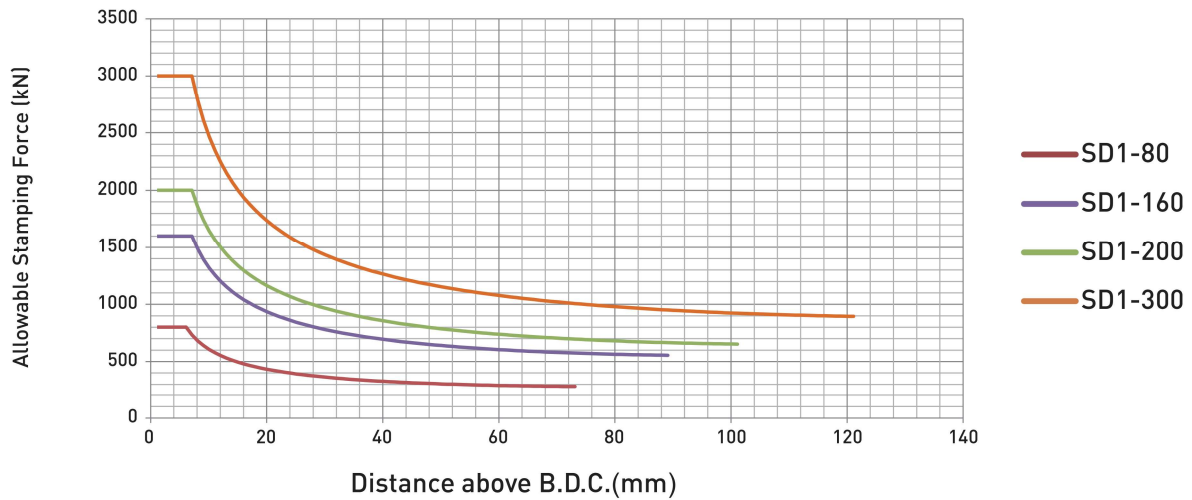

## Working Energy

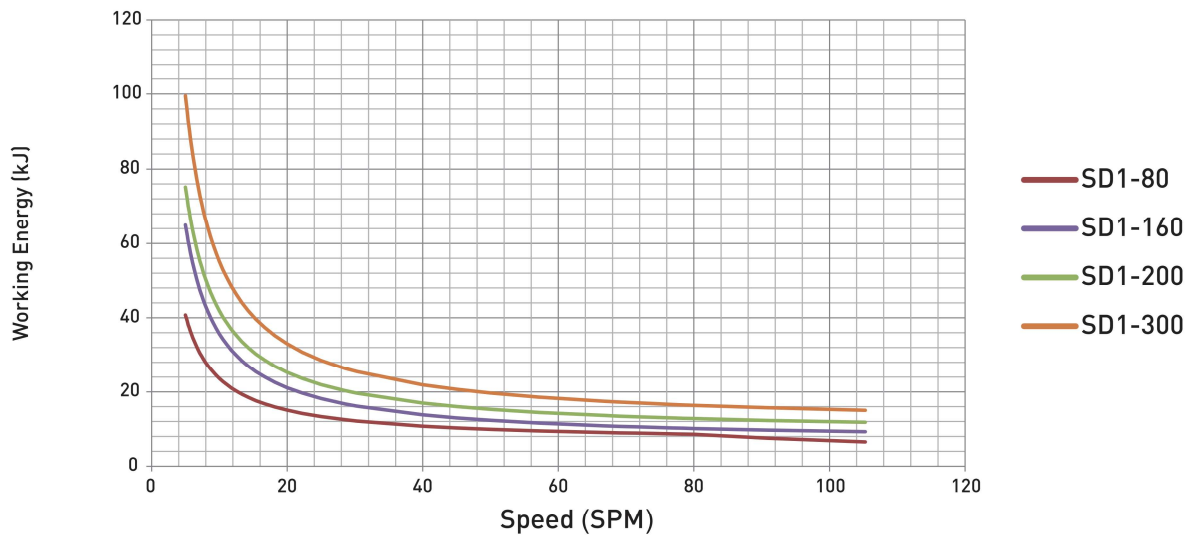

## Pendulum Motion

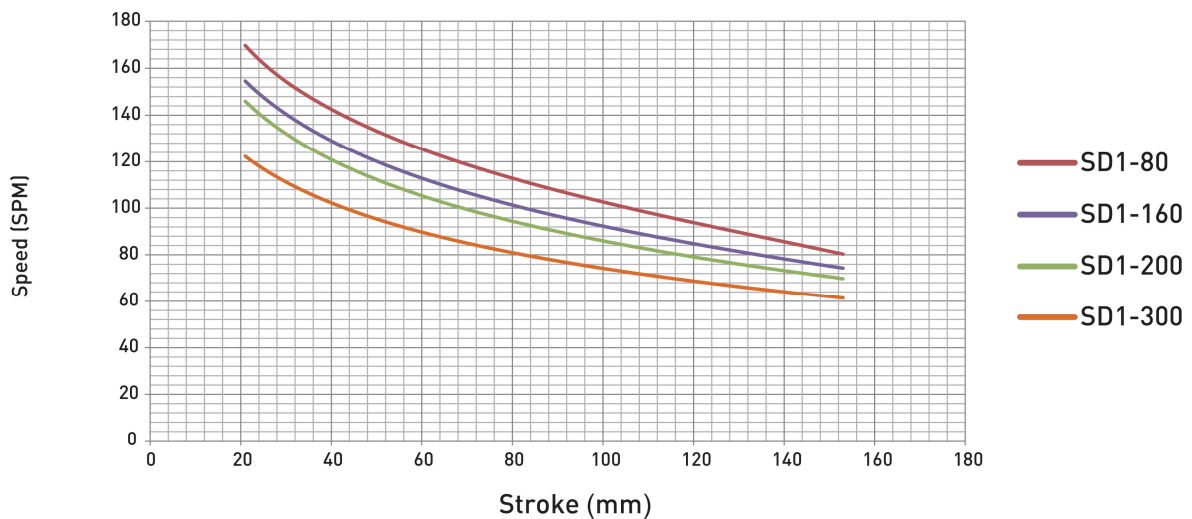

# SD2 series



Model		SD2-160	SD2-200	SD2-300	SD2-400	SD2-500
Capacity	kN	1600	2000	3000	4000	5000
Stroke Length	mm	220	250	300	350	350
Strokes per Minute	SPM	~60	~ 50	~ 40	~ 40	~ 40
Tonnage Rating Point	mm	6	6	6	6	6
Die Height	mm	450	500	600	650	650
Slide Adjustment	mm	100	110	120	130	130
Slide Area (LR x FB)	mm	1620 x 580	1900 x 670	2280 x 800	2380 x 1000	2380 x 1100
Bolster Area (LR x FB)	mm	1910 x 760	2200 x 870	2580 x 1050	2680 x 1200	2680 x 1300
Bolster Thickness	mm	160	170	200	200	200
Bolster Height (w/ Mounts)	mm	1064	1114	1264	1428	1428
Window Opening (FB x UD)	mm	760 x 400	870 x 450	1050 x 500	1200 x 550	1300 x 550
Floor Space Required	mm	2921 x 2510	3099 x 2666	3519 x 3115	3733 x 3250	4000 x 3400
Total Height (w/ Mounts)	mm	3687	4099	4710	5117	5204
Max. Upper Die Weight	kg	800	1300	1800	2500	2700
Required Air Pressure	MPa	0.5	0.5	0.5	0.5	0.5
Die Cushion	Capacity	kN	80x2	100x2	140x2	140x2
	Stroke Length	mm	110	130	140	140
	Cushion Pad Area (LR x FB)	mm	560x370x2	700x450x2	700x450x2	700x450x2

## Standard Features

- Servo System
- Safety Brake System
- Electrical Overload Protection
- Tonnage Monitor
- Programmable Motion Profiles
- Job Storage Capacity - Up to 200
- Die Height Adjustment
- Slide Position Adjustment (Handy Pulser)
- Portable Operation Stand
- Misfeed Socket
- Pneumatic ejector
- Safety Light Curtain
- Oil Lubrication System
- Total/Preset/Batch/Maintenance Counter
- Anti Vibration Mounts
- Safety Block
- Die Lamp
- Tool Box

## Optional Features

- Hydro-pneumatic Die Cushion
- Quick Die Change System
- Safety Door
- Hydraulic Die Cushion
- Lamp Socket
- NDC (Servo Die Cushion)
- Rear Safety Guard

## Slide Area & Bolster Area

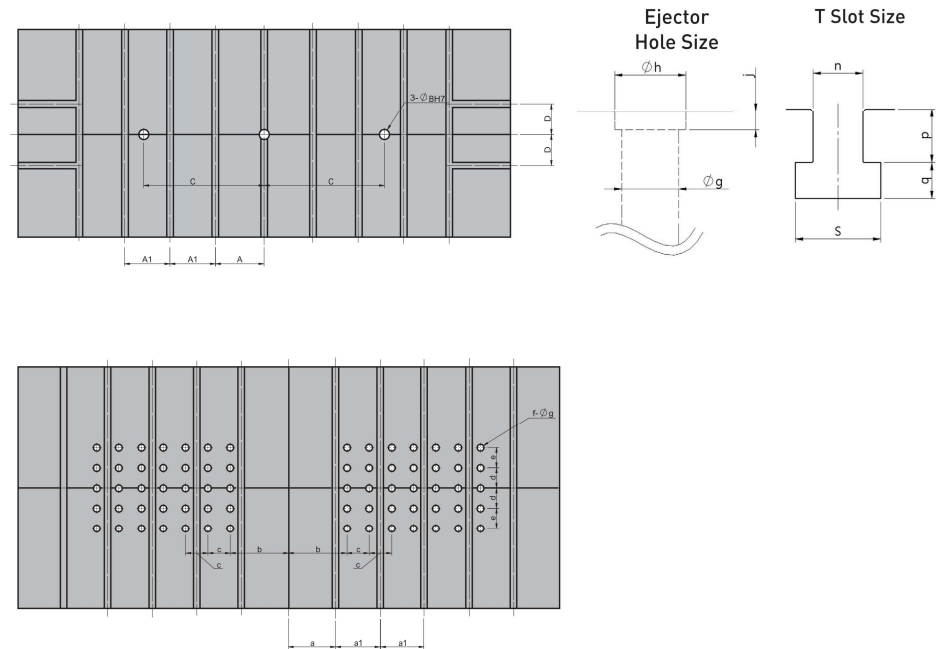

Unit: mm

Model		SD2-160	SD2-200	SD2-300	SD2-400	SD2-500
Bolster	a	200	215	235	235	235
	a1	200	220	220	220	220
	b	150	160	290	290	290
	c	100	110	110	110	110
	d	50	100	100	100	100
	e	100	100	100	100	100
	f (LRxFB)	6x4x2	7x5x2	7x5x2	7x5x2	7x5x2
	∅g	32	32	32	32	32
	∅h	40	40	40	40	40
	j	10.5	10.5	10.5	10.5	10.5
	n	28	28	28	28	28
	p	30	30	30	30	30
	q	20	20	20	20	20
s	48	48	48	48	48	
Slide Area	A	200	215	235	235	235
	A1	200	220	220	220	220
	∅B	51	51	51	51	51
	C	400	500	450	582	582
	D	125	140	150	150	150

# SD2 Series Curve Diagram

## Tonnage Curves

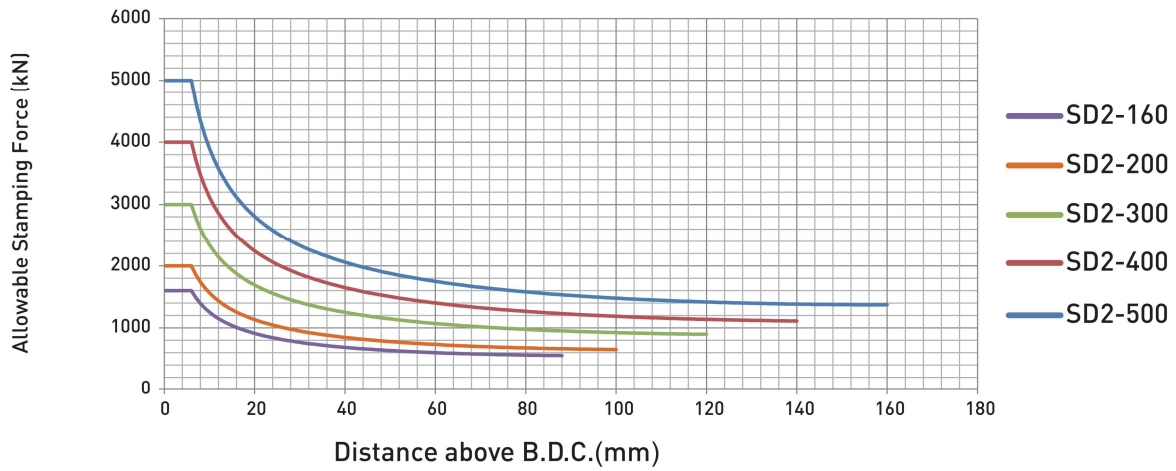

## Working Energy

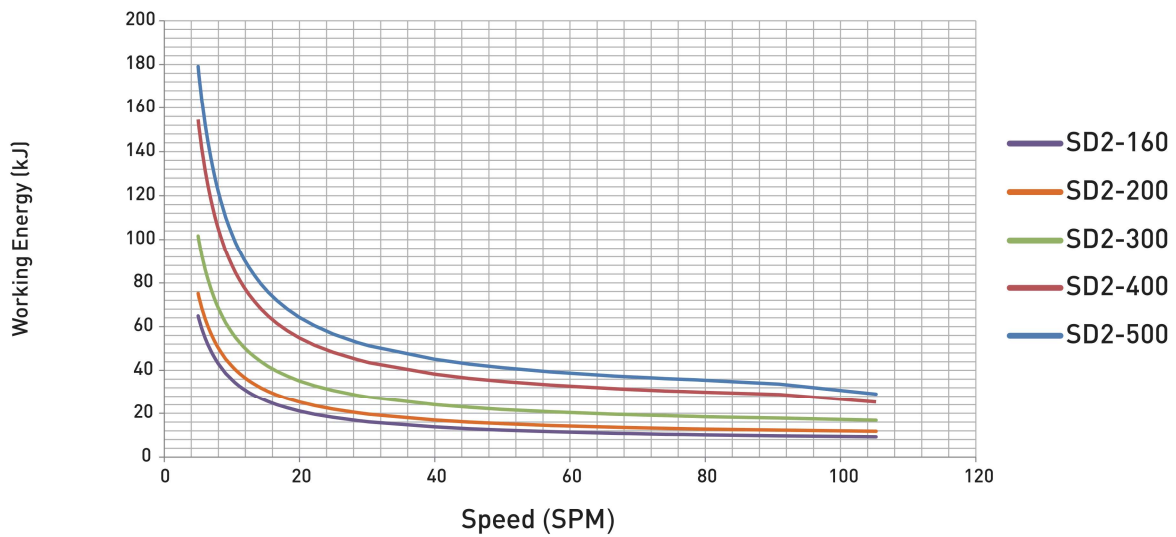

## Pendulum Motion

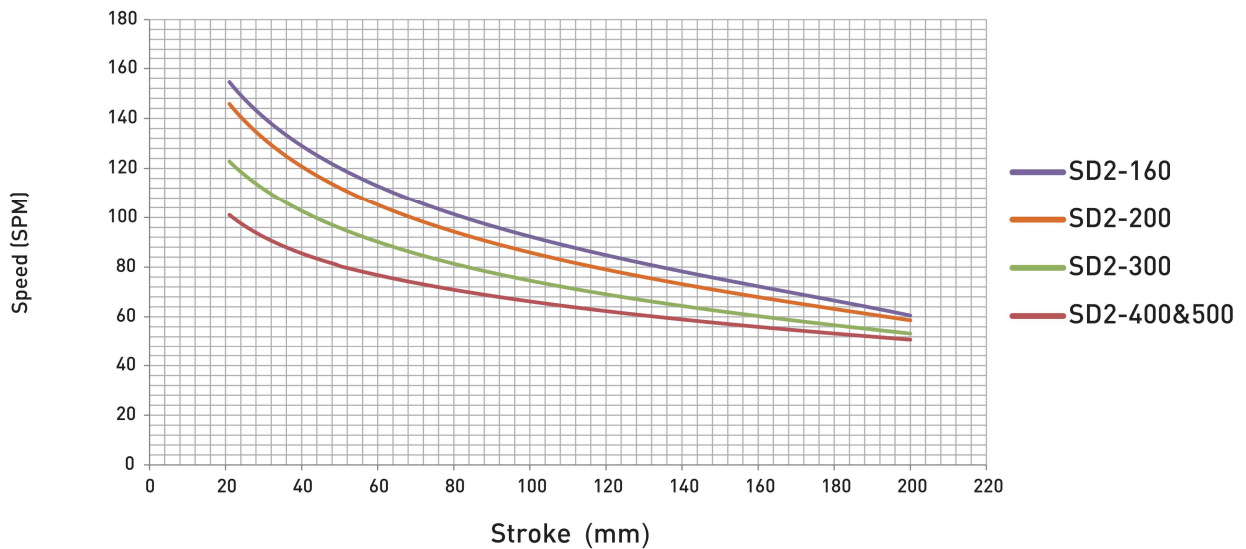

# SDG2 · SDG4 series

Model		SDG2-400	SDG2-600	SDG2-800	SDG2-1000	SDG2-1200	SDG4-400	SDG4-500	SDG4-600	SDG4-800	SDG4-1000	SDG4-1200	SDG4-1600	SDG4-2000	SDG4-2400		
Capacity	kN	4000	6000	8000	10000	12000	4000	5000	6000	8000	10000	12000	16000	20000	24000		
Stroke Length	mm	350	350	350	400	400	350	350	350	350	400	400	450	450	450		
Pendulum Motion Stroke Length	mm	100	100	100	140	140	—	—	—	—	—	—	—	—	—		
Strokes per Minute	SPM	~50	~50	~50	~50	~50	~50	~50	~50	~50	~50	~50	~40	~40	~40		
Pendulum Motion Strokes per Minute	SPM	~80	~80	~80	~80	~80	—	—	—	—	—	—	—	—	—		
Tonnage Rating Point	mm	6.5	6.5	6.5	6.5	6.5	6.5	6.5	6.5	6.5	6.5	6.5	6.5	6.5	6.5		
Die Height	mm	700	700	800	800	800	700	700	700	800	800	800	900	1000	1000		
Slide Adjustment	mm	250	250	300	300	300	250	250	250	300	300	300	300	300	300		
Slide Area (LR x FB)	1	mm	2500×1400	2500×1550	2800×1550	3100×1550	3400×1550	2500×2000	2500×2000	2500×2000	2800×2200	3100×2200	3400×2200	3400×2200	4000×2200	4000×2200	
	2		2800×1400	2800×1550	3100×1550	3400×1550	3700×1550	2800×2000	2800×2000	2800×2000	3100×2200	3400×2200	3700×2200	3700×2200	4300×2200	4300×2200	
	3		3100×1400	3100×1550	3400×1550	3700×1550	4000×1550	3100×2000	3100×2000	3100×2000	3400×2200	3700×2200	4000×2200	4000×2200	4600×2200	4600×2200	
	4		3400×1400	3400×1550	3700×1550	4000×1550	4300×1550	3400×2000	3400×2000	3400×2000	3700×2200	4000×2200	4300×2200	4300×2200	4900×2200	4900×2200	
Bolster Area (LR x FB)	1	mm	2500×1400	2500×1550	2800×1550	3100×1550	3400×1550	2500×2000	2500×2000	2500×2000	2800×2200	3100×2200	3400×2200	3400×2200	4000×2200	4000×2200	
	2		2800×1400	2800×1550	3100×1550	3400×1550	3700×1550	2800×2000	2800×2000	2800×2000	3100×2200	3400×2200	3700×2200	3700×2200	4300×2200	4300×2200	
	3		3100×1400	3100×1550	3400×1550	3700×1550	4000×1550	3100×2000	3100×2000	3100×2000	3400×2200	3700×2200	4000×2200	4000×2200	4600×2200	4600×2200	
	4		3400×1400	3400×1550	3700×1550	4000×1550	4300×1550	3400×2000	3400×2000	3400×2000	3700×2200	4000×2200	4300×2200	4300×2200	4900×2200	4900×2200	
Bolster Thickness	mm	180	250	250	250	300	180	180	250	250	250	300	300	300	300		
Window Opening	Bolster Only	(FB x UD)	mm	1100×600	1300×600	1500×700	1500×700	1500×700	1800×600	1800×600	1800×600	2000×700	2000×700	2000×700	2000×800	2000×900	2000×900
	Front to Back Rolling Bolster			1100×600	1300×600	1500×700	1500×700	1500×700	1800×600	1800×600	1800×600	2000×700	2000×700	2000×700	2000×800	2000×900	2000×900
	Left to Right Rolling Bolster			1700×800	1850×800	1850×900	1850×900	1850×900	2300×800	2300×800	2300×800	2500×900	2500×900	2500×900	2500×1000	2500×1100	2500×1100
Max. Upper Die Weight	Ton	4	5	5.5	6	7	8	8	9	10	10	11	13	15	20		
Required Air Pressure	MPa	0.6	0.6	0.6	0.6	0.6	0.6	0.6	0.6	0.6	0.6	0.6	0.6	0.6	0.6		
Bolster Height	Fixed Bolster	mm	850	850	850	850	850	660	660	660	660	740	740	740	740	740	
	Rolling Bolster		660	660	660	740	740	660	660	660	660	740	740	740	740	740	
Die Cushion	Type	Cylinder	Cylinder	Cylinder*	Cylinder*	Cylinder*	Cylinder	Cylinder	Cylinder	Cylinder	Cylinder	Cylinder	Cylinder	Cylinder	Cylinder		
	Capacity	kN	600	1000	1200**	1500	1500	600	800	1000	1200*	1500	1500	2000	2400	3000	
	Stroke Length	mm	200	200	220	220	220	200	200	200	220	220	220	220	220	250	
	Adjustment	mm	200	200	220	220	220	200	200	200	220	220	220	220	220	250	
Cushion Pad Area (LR x FB)	1	mm	2000×900	2000×950	2300×1300	2600×1300	2900×1300	2000×1300	2000×1300	2000×1300	2300×1500	2600×1500	2900×1500	2900×1500	3500×1500	3500×1500	
	2		2300×900	2300×950	2600×1300	2900×1300	3200×1300	2300×1300	2300×1300	2300×1300	2600×1500	2900×1500	3200×1500	3200×1500	3800×1500	3800×1500	
	3		2600×900	2600×950	2900×1300	3200×1300	3500×1300	2600×1300	2600×1300	2600×1300	2900×1500	3200×1500	3500×1500	3500×1500	4100×1500	4100×1500	
	4		2900×900	2900×950	3200×1300	3500×1300	3800×1300	2900×1300	2900×1300	2900×1300	3200×1500	3500×1500	3800×1500	3800×1500	4400×1500	4400×1500	

\* For selecting 1200kN, 1500kN and 2000kN air cylinder die cushions, bolster area in FB should be least 1700mm, cushion area in FB should be 1300mm.

\* For SDG4-800-1, only 1000kN die cushion is available.

\*\* For SDG2-800-1 only 1000kN die cushion is available.

※ This specification is subject to change without notice.

※ For special requirements, please contact your local supplier.

## Standard Features

---

- Servo System
- Safety Brake System
- Motorized Slide Adjustment
- Automatic Slide Adjustment
- Tonnage Monitor
- Programmable Motion Profiles
- Job Storage Capacity -up to 200 Sets
- Electronic Die Release
- Programmable Cam Switches
- Portable Operator Stand
- Electrical Overload Protection
- Automatic Recirculating Lubrication System
- Total Counter
- Preset Counter
- Maintenance Counter
- Misfeed Socket
- Air Outlet
- Air Ejector
- Anti-Repeat Safety Circuit
- Touch Panel
- Safety Fence
- Safety Block
- Ladder
- Tool Box
- Die Lamp
- Embedded Operator Console
- Safety Light Curtain
- Anti Vibration Mounts
- Automatic Counter Balance Pressure Adjustment

## Optional Features

---

- Die Cushion
- Die Cushion Stroke Adjustment
- Die Cushion Locking Device
- Die Cushion Pin Lifting Device
- Quick Die Change System
- Rolling Bolster
- Pressurized Air Supply
- Safety Door
- Safety Block (Special Type)
- Work Area Light for Front & Rear
- Remote Monitoring System



# SDE2 · SDE4 series

Model		SDE2-400	SDE2-600	SDE2-800	SDE2-1000	SDE2-1200	SDE4-400	SDE4-500	SDE4-600	SDE4-800	SDE4-1000	SDE4-1200	SDE4-1600	SDE4-2000	SDE4-2400		
Capacity	kN	4000	6000	8000	10000	12000	4000	5000	6000	8000	10000	12000	16000	20000	24000		
Stroke Length	mm	600	600	800	800	800	600	600	600	800	800	800	800	900	1000		
Strokes per Minute	SPM	~30	~30	~25	~25	~25	~30	~30	~30	~25	~20	~20	~20	~20	~20		
Tonnage Rating Point	mm	13	13	13	13	13	13	13	13	13	13	13	13	13	13		
Die Height	mm	700	800	1000	1000	1100	700	800	800	1000	1000	1100	1200	1300	1400		
Slide Adjustment	mm	300	400	500	500	500	300	400	400	400	400	500	500	600	600		
Slide Area (LR x FB)	1	mm	2500×1400	2500×1550	2800×1700	3100×1700	3400×1700	2500×2000	2500×2000	2500×2000	2800×2200	3100×2200	3400×2200	3400×2200	4000×2200	4000×2200	
	2		2800×1400	2800×1550	3100×1700	3400×1700	3700×1700	2800×2000	2800×2000	2800×2000	3100×2200	3400×2200	3700×2200	3700×2200	4300×2200	4300×2200	
	3		3100×1400	3100×1550	3400×1700	3700×1700	4000×1700	3100×2000	3100×2000	3100×2000	3400×2200	3700×2200	4000×2200	4000×2200	4600×2200	4600×2200	
	4		3400×1400	3400×1550	3700×1700	4000×1700	4300×1700	3400×2000	3400×2000	3400×2000	3700×2200	4000×2200	4300×2200	4300×2200	4900×2200	4900×2200	
Bolster Area (LR x FB)	1	mm	2500×1400	2500×1550	2800×1700	3100×1700	3400×1700	2500×2000	2500×2000	2500×2000	2800×2200	3100×2200	3400×2200	3400×2200	4000×2200	4000×2200	
	2		2800×1400	2800×1550	3100×1700	3400×1700	3700×1700	2800×2000	2800×2000	2800×2000	3100×2200	3400×2200	3700×2200	3700×2200	4300×2200	4300×2200	
	3		3100×1400	3100×1550	3400×1700	3700×1700	4000×1700	3100×2000	3100×2000	3100×2000	3400×2200	3700×2200	4000×2200	4000×2200	4600×2200	4600×2200	
	4		3400×1400	3400×1550	3700×1700	4000×1700	4300×1700	3400×2000	3400×2000	3400×2000	3700×2200	4000×2200	4300×2200	4300×2200	4900×2200	4900×2200	
Bolster Thickness		mm	180	250	250	250	300	180	180	250	250	250	300	300	300	300	
Window Opening	Bolster Only	(FB x UD)	mm	1200×600	1350×700	1500×900	1500×900	1500×1000	1800×600	1800×700	1800×700	2000×900	2000×900	2000×1000	2000×1100	2000×1200	2000×1300
	Front to Back Rolling Bolster			1200×600	1350×700	1500×900	1500×900	1500×1000	1800×600	1800×700	1800×700	2000×900	2000×900	2000×1000	2000×1100	2000×1200	2000×1300
	Left to Right Rolling Bolster			1700×800	1850×900	2000×1100	2000×1100	2000×1200	2300×800	2300×900	2300×900	2500×1100	2500×1100	2500×1200	2500×1300	2500×1400	2500×1500
Max. Upper Die Weight		Ton	5	6	7	7	8	8	9	10	10	11	13	15	20		
Required Air Pressure		MPa	0.6	0.6	0.6	0.6	0.6	0.6	0.6	0.6	0.6	0.6	0.6	0.6	0.6		
Bolster Height	Fixed Bolster	mm	850	850	850	850	850	660	660	660	660	740	740	740	740	740	
	Rolling Bolster		660	660	660	740	740	660	660	660	660	740	740	740	740	740	
Die Cushion	Type	Cylinder															
	Capacity	kN	600	1000	1200	1500	1500	600	800	1000	1200*	1500	1500	2000	2400	3000	
	Stroke Length	mm	200	200	220	220	220	200	200	200	220	220	220	220	220	250	
	Adjustment	mm	200	200	220	220	220	200	200	200	220	220	220	220	220	250	
Cushion Pad Area (LR x FB)	1	mm	2000×900	2000×950	2300×1300	2600×1300	2900×1300	2000×1300	2000×1300	2000×1300	2300×1500	2600×1500	2900×1500	2900×1500	3500×1500	3500×1500	
	2		2300×900	2300×950	2600×1300	2900×1300	3200×1300	2300×1300	2300×1300	2300×1300	2600×1500	2900×1500	3200×1500	3200×1500	3800×1500	3800×1500	
	3		2600×900	2600×950	2900×1300	3200×1300	3500×1300	2600×1300	2600×1300	2600×1300	2900×1500	3200×1500	3500×1500	3500×1500	4100×1500	4100×1500	
	4		2900×900	2900×950	3200×1300	3500×1300	3800×1300	2900×1300	2900×1300	2900×1300	3200×1500	3500×1500	3800×1500	3800×1500	4400×1500	4400×1500	

※ This specification is subject to change without notice.

※ For special requirements, please contact your local supplier.

\* For SDE4-800-1, only 1000kN die cushion is available.

## Standard Features

---

- Servo System
- Safety Brake System
- Motorized Slide Adjustment
- Automatic Slide Adjustment
- Tonnage Monitor
- Programmable Motion Profiles
- Job Storage Capacity -up to 200 Sets
- Electronic Die Release
- Programmable Cam Switches
- Portable Operator Stand
- Electrical Overload Protection
- Automatic Recirculating Lubrication System
- Total Counter
- Preset Counter
- Maintenance Counter
- Misfeed Socket
- Air Outlet
- Air Ejector
- Anti-Repeat Safety Circuit
- Touch Panel
- Safety Fence
- Safety Block
- Ladder
- Tool Box
- Die Lamp
- Embedded Operator Console
- Safety Light Curtain
- Anti Vibration Mounts
- Automatic Counter Balance Pressure Adjustment

## Optional Features

---

- Die Cushion
- Die Cushion Stroke Adjustment
- Die Cushion Locking Device
- Die Cushion Pin Lifting Device
- Quick Die Change System
- Rolling Bolster
- Pressurized Air Supply
- Safety Door
- Safety Block (Special Type)
- Work Area Light for Front & Rear
- Remote Monitoring System

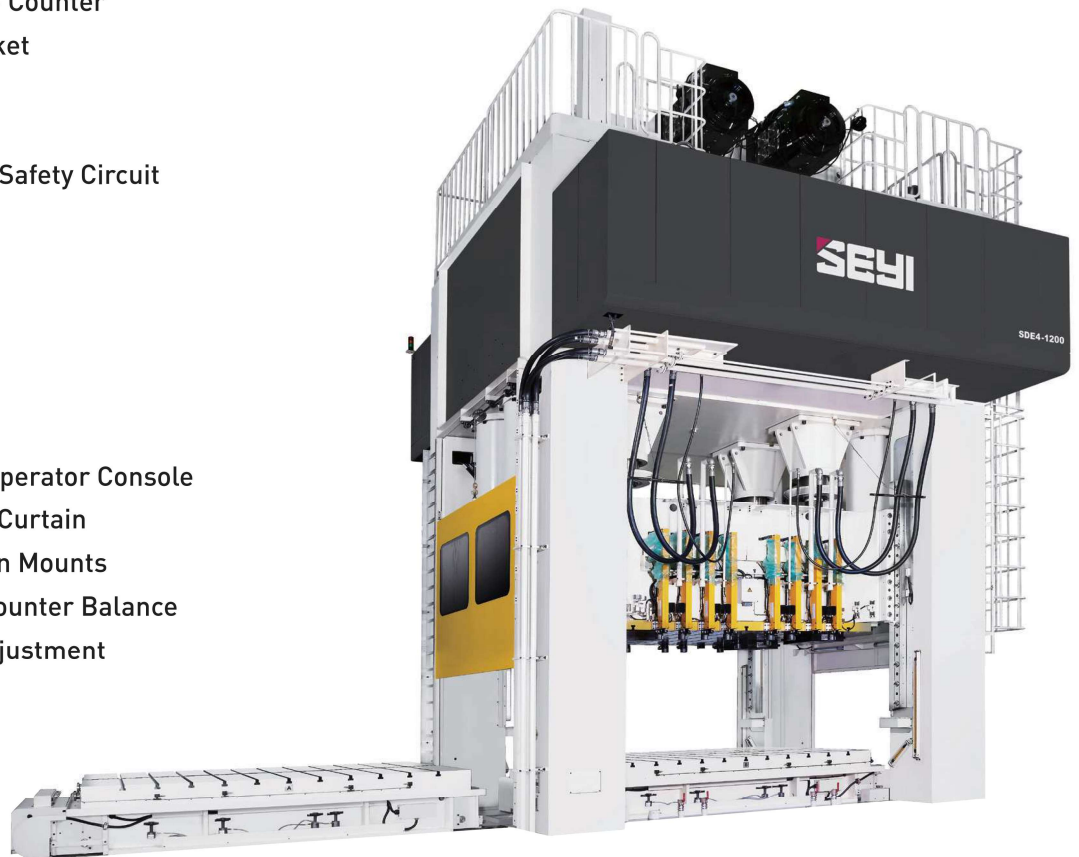

# SEYI Servo Press is your first step toward Smart Factory

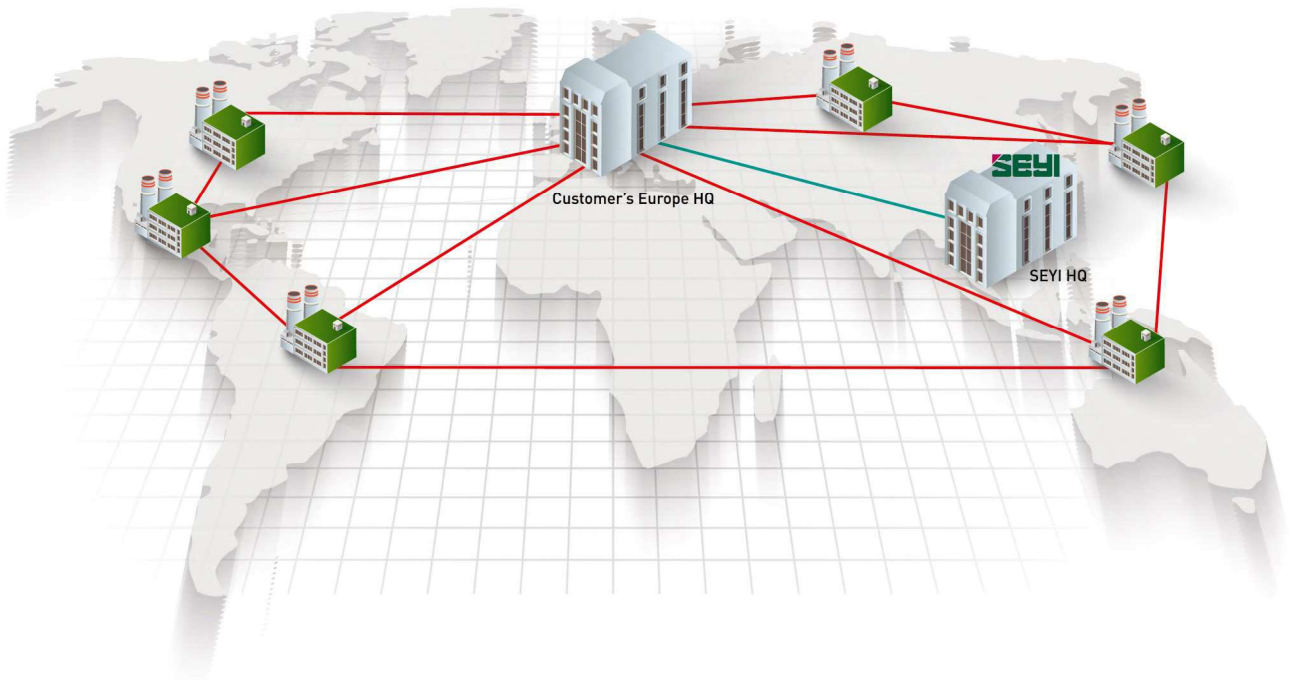

SEYI's servo system is designed to assist our customers in moving towards smart manufacturing systems. Flexible and extendable software design makes our press more intelligent. Real-time press status monitoring and remote repair can be done from anywhere in the world. This can assist the customers, especially multinational corporations, to monitor their production status in different countries and enhance global management efficiency.

## Production Monitoring & Troubleshooting

- Production status monitoring
- Machine status monitoring and error reporting
- Quick response for troubleshooting and tracking
- History management

## Intelligent Systems & Preventive Maintenance

- Auto adjustment to the optimal production condition
- Die protection
- Quality control monitoring
- Self-diagnosis and alert system



SHIEH YIH MACHINERY INDUSTRY CO., LTD. (HEADQUARTERS)

---

XIE YI TECH MACHINERY (CHINA) CO., LTD

---

SEYI-AMERICA, INC.

---

SEYI MÉXICO

---

SEYI PRESSES EUROPE GMBH

---

SEYI (THAILAND) CO., LTD

---

[www.seyi.com](http://www.seyi.com)

